

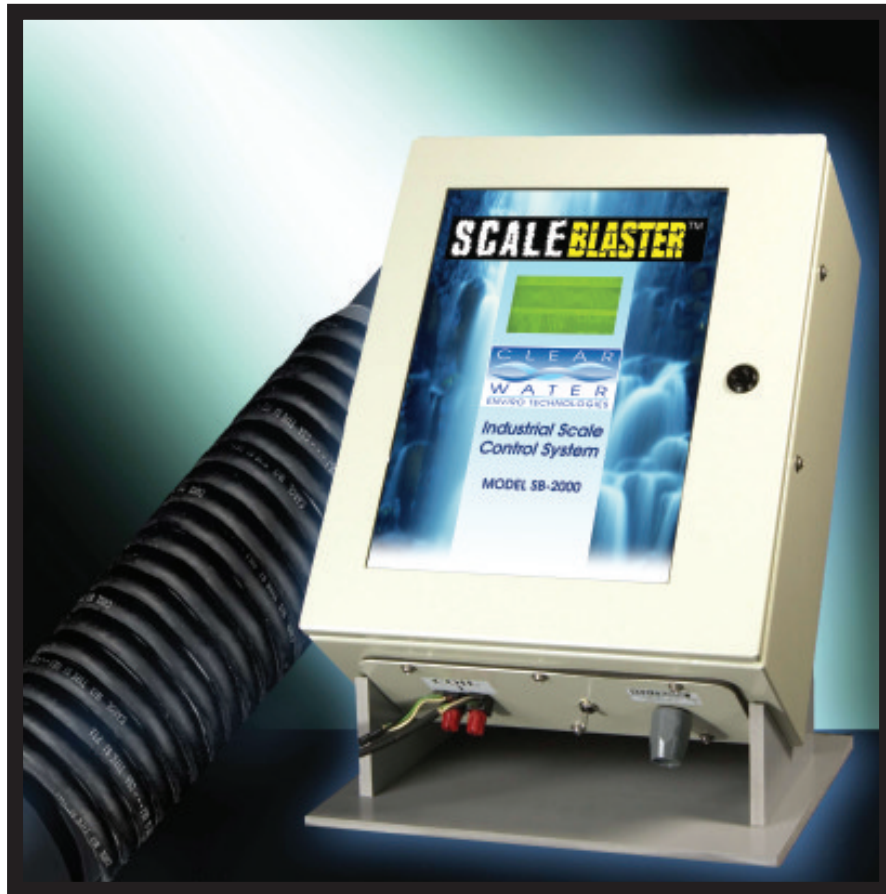

SCALE BLASTER™

SB-2000

Installation & Operation Manual



Industrial Electronic Descaler

115/230 VAC

For pipe sizes up to: 20" -non-ferrous

8-14" -ferrous

Table of Contents

Section	Description	Page
A)	Unpacking and Identifying the Scaleblaster components.....	4
B)	Installing the Scaleblaster Control Box.....	5
C)	Wrapping the Signal Coil.....	6,7
D)	Powering up the Control Box.....	8
E)	LCD Indicator Screen.....	8
F)	Error Screen and Codes.....	9
G)	Calibrating the Signal Coil.....	10,11
H)	Adjusting the LCD Contrast.....	12
I)	Changing the Frequency Sweep Mode.....	12
J)	Attaching an External Alarm/Fault Indicator.....	13
Appendix 1)	Model Number Dip Switch Settings.....	14
Appendix 2)	Frequency Sweep Dip Switch Settings.....	15
Appendix 3)	Unit Specifications.....	16
Notes)	_____	17,18

Product Information



A) Unpacking/Identifying the Scaleblaster™ components

The ScaleBlaster™ unit includes the following components:

- 1.) One ScaleBlaster™ control box.
- 2.) **One roll of black, 18/3-conductor signal cable.** The total length of the cable will depend on the diameter and composition of the pipe to which it will attach.
- 3.) **Several long nylon cable ties.** These ties aid in securing the cable to the pipe.
- 4.) **Warranty card (along with this Installation & Operations Manual).**
- 5.) **Shipping Box.** Please save the shipping container, it is made to protect the descaler during transport and is reusable in case the unit needs servicing at the factory.



1



2



3



5



4

B) Installing the Scaleblaster™ Control Box

Selecting the Installation Location and Mounting the ScaleBlaster™ Unit

PLEASE READ THE ENTIRE MANUAL BEFORE BEGINNING INSTALLATION. THE LOCATION OF THE SIGNAL CABLE AND THE CONTROL BOX ARE CRITICAL WITH RESPECT TO PRODUCT PERFORMANCE.

- 1.) The unit should be installed by a licensed electrician, and the installation should meet all local and national codes.
- 2.) The best place to install the unit is on the main water line entering the facility, or on the line serving the relevant portion of the facility. First determine where the signal coils will be wrapped. This should be on a straight section of pipe (no elbows, tees, valves or couplings) that is at least four (4) feet long. Also, very important, the signal coils should be at least three (3) feet from any major source of electrical interference. The unit is splash-proof and can be installed outside if necessary. However, in this case a cover should be installed above the unit, and the unit should be kept out of direct sunlight.
- 3.) Mount the control box as close as possible to where the signal cable will wrap on the pipe, so that the cable is as short as possible.
- 4.) The control box, which has a 15-ft. power cord, should be mounted on a wall or other solid surface in a location near an electrical outlet or other power source. The unit is heavy and a sturdy installation is required. We recommend that you use a 3/8" lag and washer for each of the four mounting feet. (See photos below.)
- 5.) Upon being plugged in, the unit will work automatically on either 115 VAC or 230 VAC.

NOTE: If you have any questions about installation, contact your dealer or **Clearwater Enviro Technologies, Inc.** for assistance.



Photo 1 - recommended 3/8" mounting lag with washer.



Photo 2 - one of the four control box mounting feet.

C) Wrapping the Signal Coil

Wrapping the Signal Cable Around the Pipe

Included with the unit is one roll of black, 3-conductor signal cable whose length is based on the size and composition of the pipe selected for installation.

1.) Carefully strip off 2" (51mm) of the outer rubber shield from the end of the signal cable. Next, strip off 2" (51mm) of the insulation from each of the three conductor wires (black, white and green). Splice the three wires together tightly (see **Photo 3, below**).

2.) Unscrew the first of the two receptacle posts for that coil (see **Photo 5, next page**) by turning it counter-clockwise to create an opening. Then, with the spliced wires of the signal cable completely threaded through the opening, tighten the receptacle post as much as possible (see **Photo 3, below**).

3.) Route the signal cable from the control box to the inlet pipe. Hold the cable parallel and against the pipe and then secure the cable to the pipe with one of the nylon cables ties. Make sure that the tie is pulled tightly so that the cable is well-attached to the pipe. Remove excess cable tie with scissors.

4.) Using finger pressure to keep the signal cable and tie from moving, begin wrapping the signal cable securely around the pipe in any direction. The correct number of wraps depends on pipe size and composition. For proper product performance, it is imperative to wrap the correct number of times. To determine the number of wraps for ferrous pipe, consult **Table 1** (below). For non-ferrous pipe, please call **ClearWater Enviro Technologies, Inc.** to get this information.

5.) **MAKE SURE THAT THE WRAPS ARE FLUSH AGAINST ONE ANOTHER—NEVER OVERLAPPING** (see **Photo 4a & 4b, next page**).

NOTE: As previously indicated, make sure that the control box is mounted as close as possible to where the signal cable is wrapped on the pipe.

Pipe Size	Nominal Pipe OD	Circumference	Number of Wraps	Total Length Coil Only	Total Length w/ 15' Coil Leads
8" / (20.32cm)	9" / (21.59cm)	26.7" / (67.82cm)	43	96' / (243.04cm)	126' / (319cm)
10" / (25.4 cm)	11" / (27.31cm)	33.77" / (85.78cm)	40	113' / (285.93cm)	143' / (362cm)
12" / (30.48cm)	13" / (33.02cm)	40.84" / (103.73cm)	37	126' / (319.84cm)	156' / (396cm)
14" / (35.56cm)	15" / (38.1 cm)	47.12" / (119.69cm)	34	134' / (339.12cm)	164' / (415cm)

Table 1 - Ferrous Pipe: Number of Wraps by Pipe Size

6.) Once the wrapping is complete, secure the signal cable to the pipe using another cable tie. Remove the excess cable tie with scissors.

7.) Route the loose end of the signal cable back to the control box. Trim the cable to length.

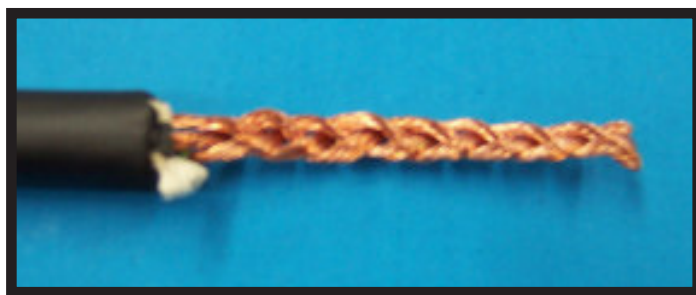

Photo 3 - Signal coil end with three wires stripped and braided together

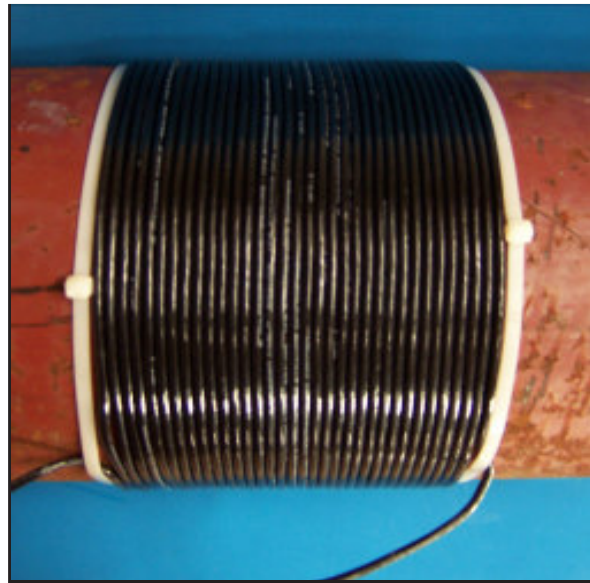

Photo 4a & 4b - Examples of tightly wrapped coils

Channel One Output Binding Post Set: Connect first signal cable to these binding posts.

Power Switch

Model and Serial Number Label

Gland Plate



K-Flex Conduit Connector

Photo 5 - Unit Gland Plate

Main Input Cable:
90-264 VAC, 47-63Hz

D) Powering Up the Control Box

Power Requirements and Considerations for the ScaleBlaster™ Control Box

- 1.) The unit will work automatically on either 115 or 230 VAC. Since electrical outlets vary worldwide, the power cord plug may not match your outlet type. In this case, it must be replaced with the proper plug by a licensed electrician.
- 2.) Plug the power cord into the outlet.
- 3.) Turn the power toggle switch upward to the “ON” position.

E) LCD Indicator Screen

This ScaleBlaster™ unit has an LCD screen on the front of the control box that provides information on operation on the descalers operational condition.

Start-up Screen

The start-up screen is displayed for approximately 10 seconds while the unit initializes.



Firmware Revision Level

Total Hours of Operation

Main Screen

The main screen shows most of the operation condition of the Scaleblaster control box.

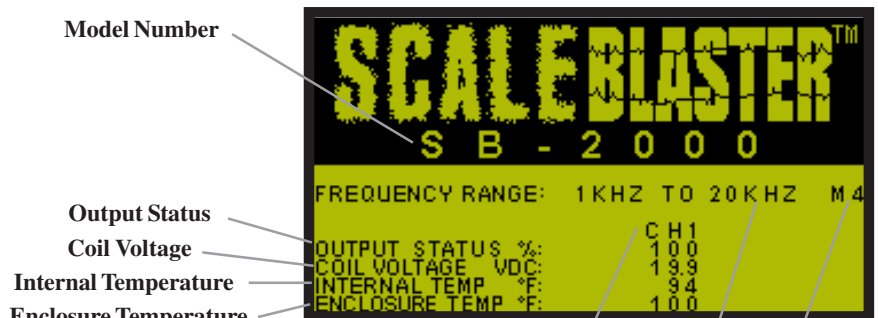

Channel Number

Frequency Sweep Range

Frequency Sweep Range Mode Number

Descriptions of some of the screen indicators:

Model Number: ScaleBlaster™ ‘industrial’ models include the SB-1200, SB-1400, SB-1800, SB-2000, SB-2800, SB-3600, and SB-4000.

Output Status: Output status of the coil current. The value of “100” indicates that the unit is functioning at 100%.

Coil Voltage: This is the voltage applied to the induction coil (i.e., the coiled wraps on the pipe). These values should always be between 19.5 and 20.5 volts direct current.

Internal Temp: This value indicates the internal temperature in degrees Fahrenheit.

Enclosure Temp: Displays the temperature, in degrees Fahrenheit, of each channel’s heatsink.

Frequency Sweep Range: Frequency range the descalers output will sweep between.

Mode Number: This number identifies a particular frequency sweep range, as set by the DIP switch. The unit is designed to permit selecting from among several pre-set sweep ranges via the DIP switch. (See “Additional Options: Frequency Sweep Mode”, p. 12.)

F) Error Screen and Codes

This ScaleBlaster™ unit constantly scans for any malfunctions in the operation status of the unit. If an error is detected it is logged reported via the *Unit Error Screen*. This screen will display the channel and error that has occurred. A brief description of these errors are described below.

Error List: Displays channel number and type of error that has occurred. List holds up to four errors.

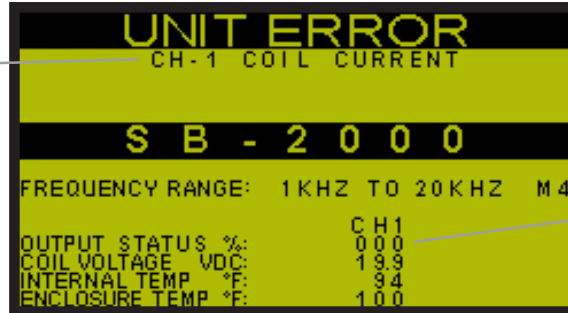

Error: In this example, the reading of “000” for the output status indicates a problem with the current at the coil for Channel 1.

Sample Error Screen

INTERNAL TEMP Error

Displayed as: CH-1 INTERNAL TEMP

The internal temperature sensor has recorded a temperature that is too high (above 150° F , 65.6° C) and has shut down that channel. One possible cause for this error is that the unit was installed in a location exposed to direct sunlight, which may make the unit overheat. Another possible reason for this is a failure of internal circuitry causing excess heat buildup. In this case, contact your dealer or **ClearWater Enviro Technologies, Inc.**

ENCLOSURE TEMP Error

Displayed as: CH-1 ENCLOSURE TEMP

Enclosure and slave board heatsink temperature sensor has recorded a temperature that is too high (above 150° F , 65.6° C) and has shut down that channel. Possible cause for this error: internal circuitry failure. Contact your dealer or **ClearWater Enviro Technologies, Inc.**

SMPS VOLTAGE Error

Displayed as: CH-1 SMPS VOLTAGE

The value shown at “Coil Voltage” is the main output in volts from the Switch Mode Power Supply located inside the control box. If this error occurs, check the output binding posts for that channel to make sure that they are not directly shorted together. If not, then there must be a failure of internal circuitry. Contact your dealer or **ClearWater Enviro Technologies, Inc.**

COIL CURRENT Error

Displayed as: CH-1 COIL CURRENT

This indicates a failure in the main output current for that channel. Possible cause: the cable wire has been cut or disconnected from the output binding post.

G) Calibrating the Signal Coil

Calibrating the Industrial unit to match Coil / Pipe Variations

The unit has been factory calibrated to the pipe similar to that of the actual installed pipe. However there may be differences in the pipe material, pipe wall thickness, and coil wrapping techniques which may require the unit to be re-calibrated. The following will instruct the installer how to accomplish this task. Tools required, a large regular screw driver, and a small jewelers screw driver. **Note that even though the instructions are using different models to show the calibration process, the process is virtually identical for each model.**

Step 1) Make sure unit is at room temperature, **DO NOT** calibrate unit while the unit is warm. Please wait till the unit has returned to room temperature. Then, open the door on the unit using the large regular screw driver.



Control unit with door closed.

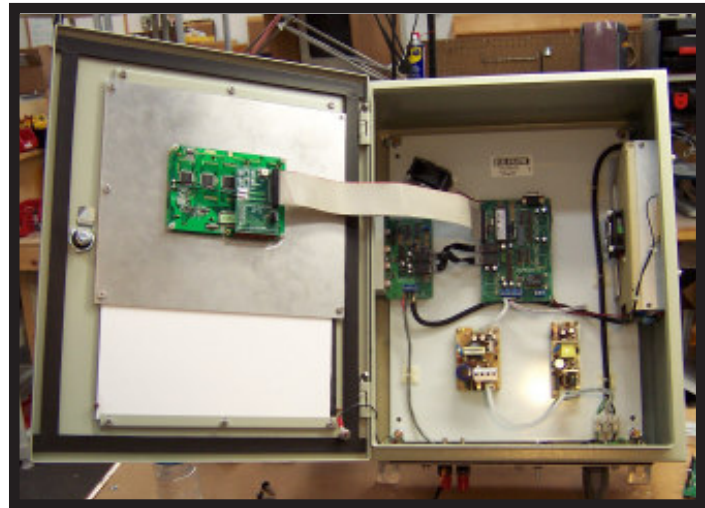

Control unit door open showing electronics inside.

Step 2) Use the small jewelers screwdriver to move the bottom four dip switches to the positions shown in the picture below.

Note: DO NOT move any of the top four dip switches.

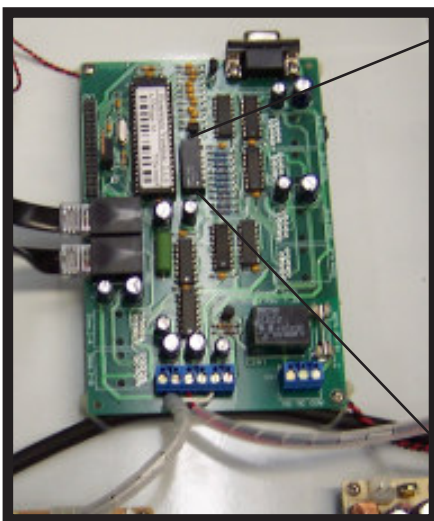

View of the master board showing location of Dip Switch.

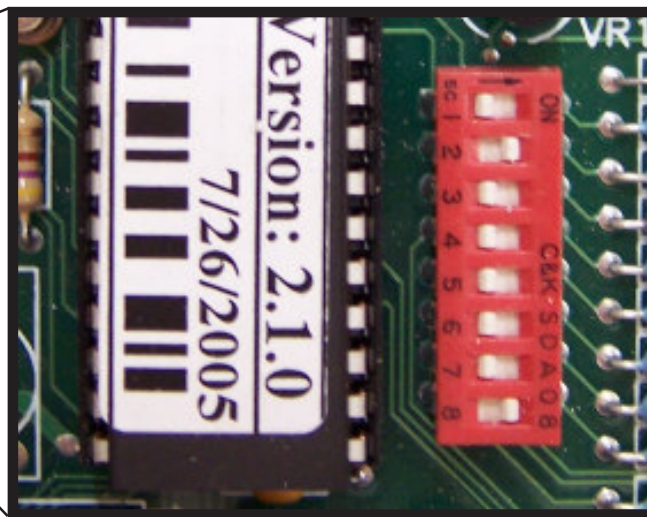

Close up view of the dip switch Set for calibration mode.

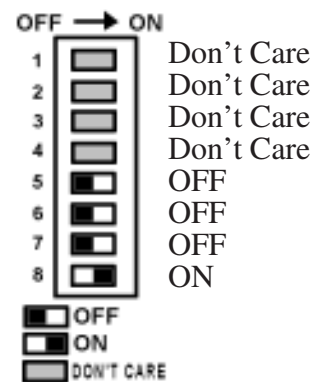

G) Calibrating the Signal Coil

(Continued)

Step 3) Locate the slave board, and the small blue potentiometer located at the upper right side of that board.



View showing all boards.

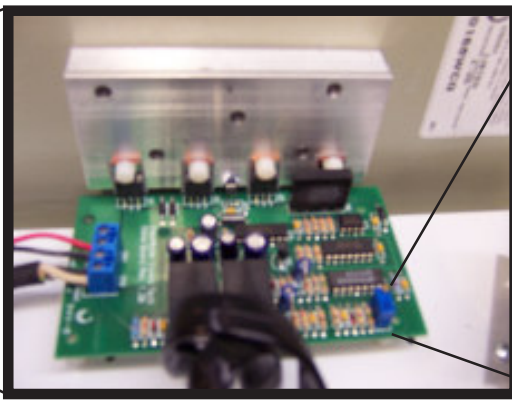

Close up view of slave board.



Close up view of potentiometer on slave board.

Step 4) With the coil attached, power up unit and notice that it now comes up in calibration mode (M9).

Step 5) Now the unit is in calibration mode, the output power reading is changed in this mode to display the under/over current error trip point. This reading should be between 40 and 60. If output power is lower than 040, then using the small jewelers screwdriver, turn the small screw on the blue potentiometer, (the blue square thing) clock wise, this will increase the output power reading. Likewise if the output power reading is more than say 060, adjust the potentiometer counter clockwise till it is between 40-60. Please note that the exact reading is not critical, and where from 40 to 60 will allow the unit to operate with in the normal operating parameters.



View of the units screen in normal mode (M4).

Note if the unit is not responding to the above calibration then, turn the potentiometer 20 full turns counter-clockwise. This will reset the unit to its default minimum value. Then repete step 5.

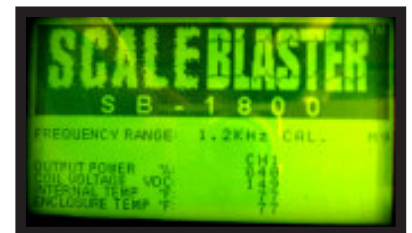

View of the units screen in calibration mode (M9).

Note this will not increase the output power. This adjustment is for the internal microcontroller reference for sensing over and under current conditions and has

Step 6) Once the adjustment has been made, power down unit and reset the bottom four dip switches back to the normal operating mode, 1KHz to 20KHz (M4).

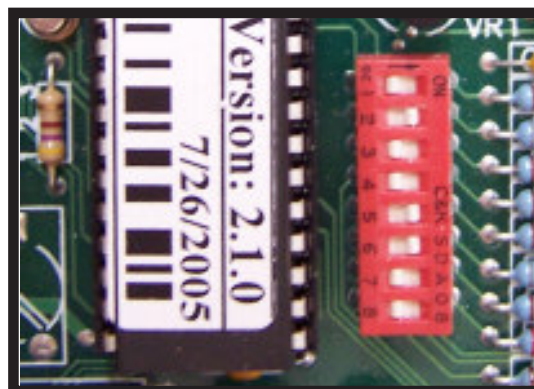

View of the Dip Switch Set for normal mode.

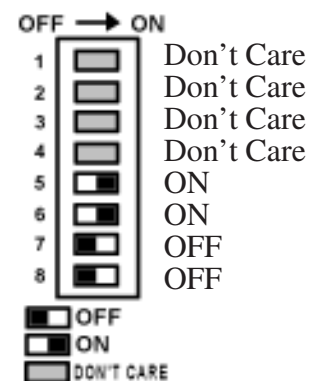

H) Adjusting the LCD Contrast

Depending on light conditions of the control boxes installation site, it might be necessary to adjust the LCD's contrast. To adjust the contrast of the LCD, first locate the Contrast Adjustment Control. Using a small, flathead screwdriver, rotate the control until the desired contrast is achieved.



Back of door showing the LCD Display Board

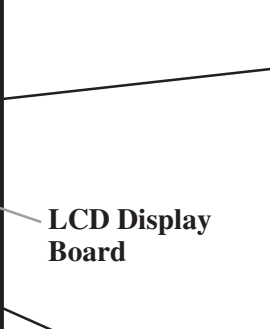

LCD Display Board



Close-up of LCD Display Board showing the Contrast Control

I) Changing the Frequency Sweep Mode

This unit has a patent-pending feature that allows you to adjust the frequency sweep range via the DIP switch (below). The range has been factory set, and we recommend that you do not change this without first consulting ClearWater's engineers.

Main Control PC Board



View of Main Control PC Board



Close-up view showing DIP Switch

DIP Switch

J) Attaching an External Alarm/Fault Indicator

All units come with the option of adding an alarm or fault indicator to instantly alert you of any power failure or equipment malfunction. The Terminal Strip (shown below) permits the addition of any type of external alarm system, light, or dial-up to a phone, beeper, etc. Provided these components do not exceed 240vac @ 10amp, and are not inductive in nature. Contact your dealer or **ClearWater Enviro Technologies, Inc.** for more details.

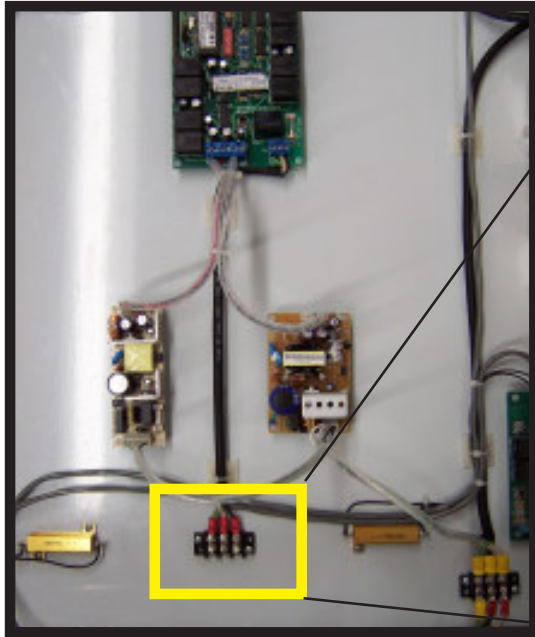

Location of Terminal Strip



Close-up view of Terminal Strip

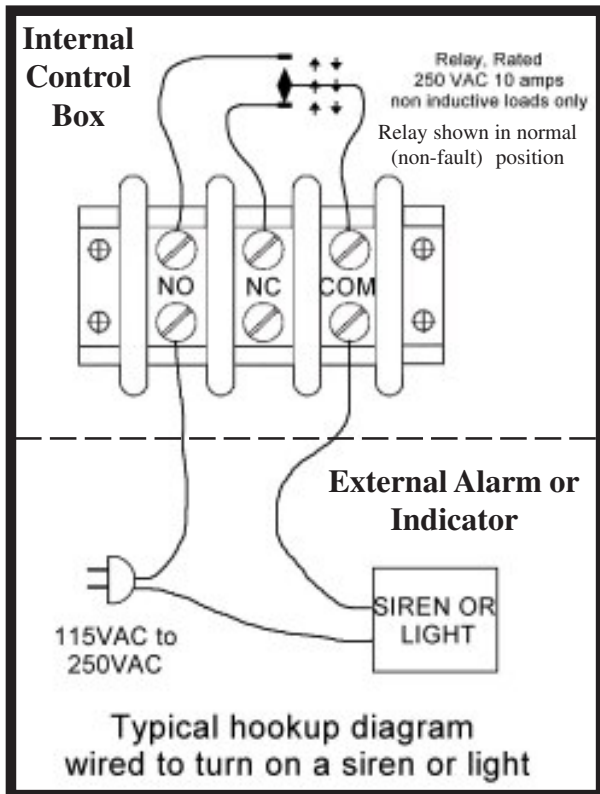
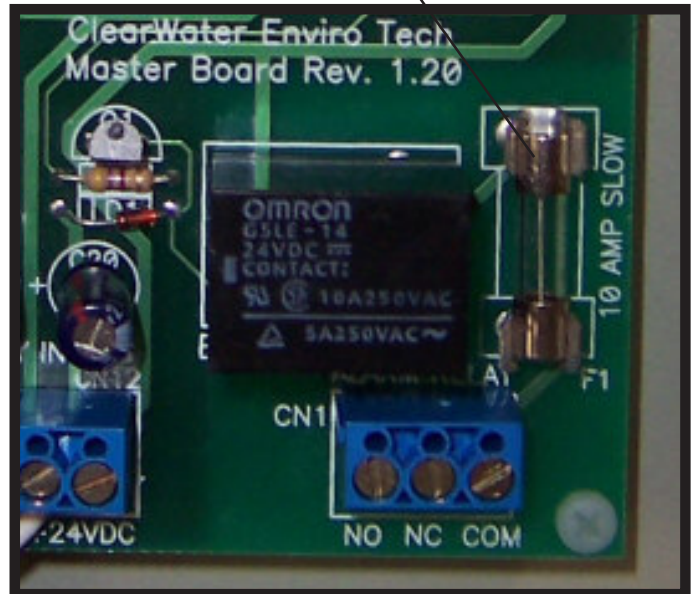

Diagram showing a typical hookup for a light or siren to activate if a unit fault is detected.

Alarm fuse, 10amp, 240VAC, Slow Blo, 5x20mm



Alarm Relay and Fuse location.

Appendix 1) Model Number Dip Switch Settings

This is factory set and should not be adjusted by the end user. These switches will not increase the power to the unit, that can only be done at the factory. These settings are only for reference in the case that they were altered by mistake.

SB-1200 Mode

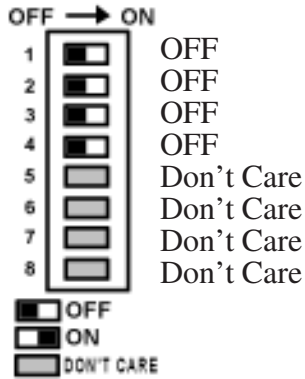

SB-1400 Mode

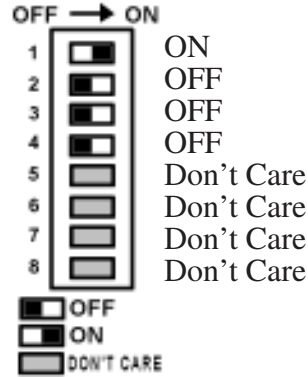

SB-1800 Mode

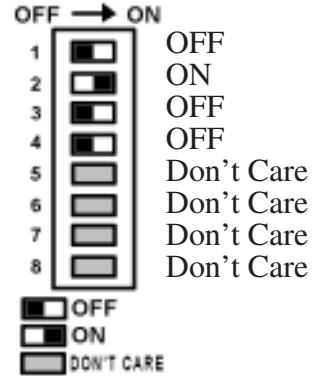

SB-2000 Mode

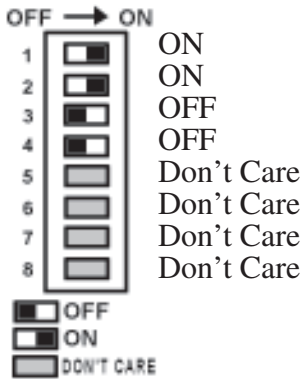

SB-2800 Mode

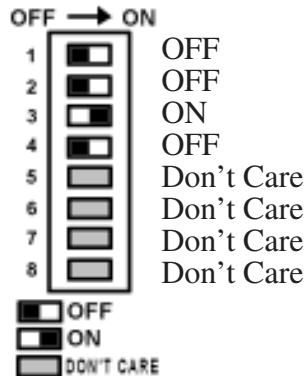

SB-3600 Mode

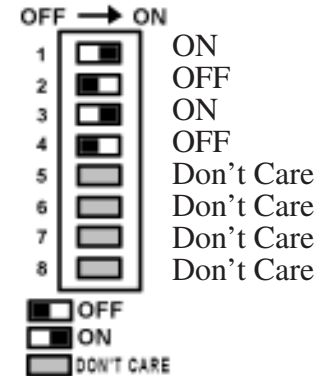

SB-4000 Mode

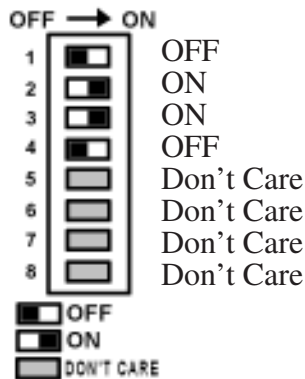

Appendix 2) Frequency Sweep Dip Switch Settings

This is factory set and should not be adjusted by the end user. These switches will not increase the power to the unit, that can only be done at the factory. These settings are only for reference in the case that they were altered by mistake.

Mode 1 - 1KHz to 5KHz

Sets the frequency sweep range of the unit to sweep from 1,000 hertz to 5,000 hertz.

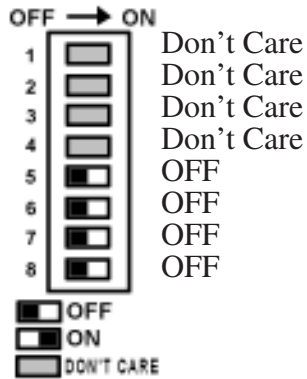

Mode 2 - 1KHz to 10KHz

Sets the frequency sweep range of the unit to sweep from 1,000 hertz to 10,000 hertz.

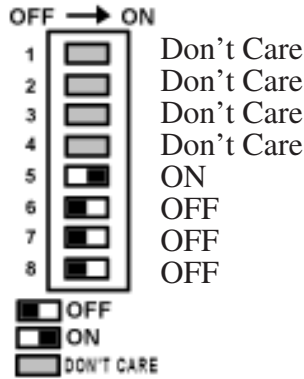

Mode 3 - 1KHz to 15KHz

Sets the frequency sweep range of the unit to sweep from 1,000 hertz to 15,000 hertz.

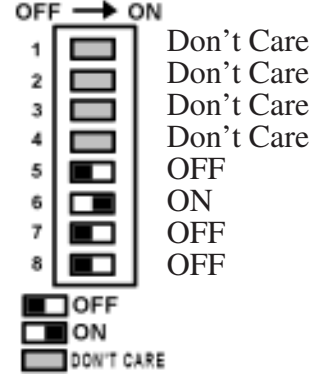

Mode 4 - 1KHz to 20KHz

Sets the frequency sweep range of the unit to sweep from 1,000 hertz to 20,000 hertz.

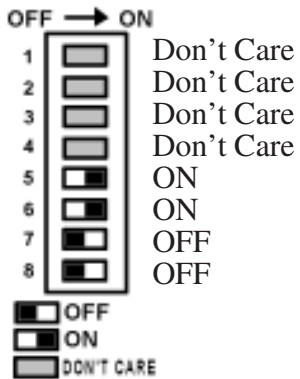

Mode 5 - 1KHz to 2KHz

Sets the frequency sweep range of the unit to sweep from 1,000 hertz to 2,000 hertz.

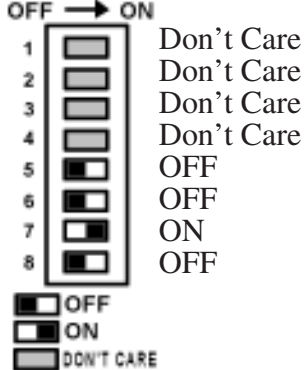

Mode 6 - 2KHz to 4KHz

Sets the frequency sweep range of the unit to sweep from 2,000 hertz to 4,000 hertz.

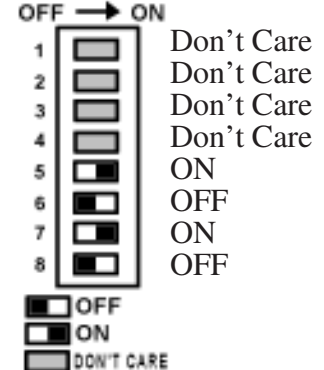

Mode 7 - Cal. Auto Tune

Future Use

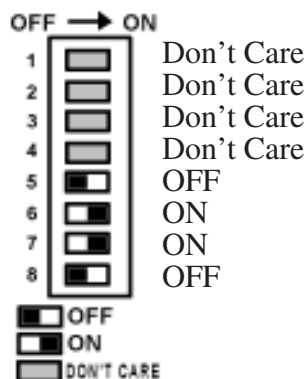

Mode 8 - Use Auto Tune

Future Use

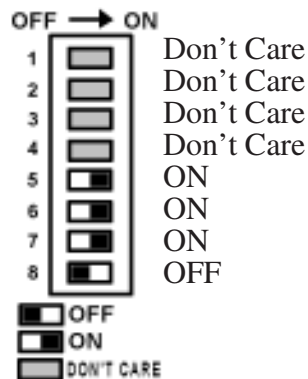

Mode 9 - Calibrate Coil

Use to calibrate the signal coil to the Scaleblaster unit.

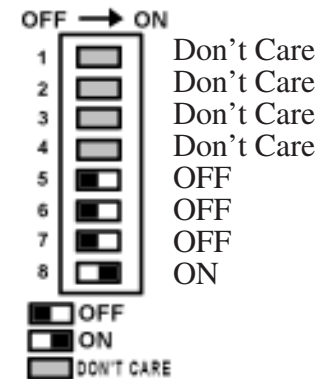

Appendix 3) Unit Specifications

SB-2000 Electronic Descaler Specification Sheet

<u>Input Voltage:</u>	90-264 VAC at 47-63 Hz
<u>Input Current:</u>	2A rush @ 115 VAC, 1A rush @ 230 VAC
<u>No. Channels:</u>	One
<u>Output Voltage:</u>	20 VDC
<u>Output Current:</u>	10 Amps Peak Min. @ 1KHz**
<u>Output Signal:</u>	AC Square wave, Frequency user selectable: Swept frequency from 1KHz to 5KHz Swept frequency from 1KHz to 10KHz Swept frequency from 1KHz to 15KHz Swept frequency from 1KHz to 20KHz Swept frequency from 1KHz to 2KHz Swept frequency from 2KHz to 4KHz

Circuit Protection:

- Thermal overload protection on Switch-Mode Power Supply (SMPS)
- Over voltage protection on SMPS
- Over current protection on SMPS
- Micro-controller monitoring of enclosure/heatsink over temperature shutdown
- Micro-controller monitoring of internal over temperature shutdown
- Output sensing circuit for over current immediate shutdown protection
- Main input noise filtering

Enclosure: Wall mount, beige powder-coated, 16-gauge steel. Nema 4 and 12 rated. With Gland Plate and polycarbonate window.

Operating Temperature: 10° F to 130° F (12° C to 54° C)

Storage Temperature: 2° F to 150° F (17° C to 66° C)

Physical Properties:

SB-2000 Unit Dimensions: 20"x16"x8" (50.8cm x 40.6cm x 20.3cm)

SB-2000 Unit Weight: 35 LBS (15.9 Kg)

SB-2000 Shipping Box Dimensions: 27"x22"x17"

SB-2000 Shipping Weight: 60 LBS*

* Estimated shipping weight. (Varies with differing amounts of signal cable.)

** Maximum coil inductance: 200uH. (See coil chart.)



Clearwater Enviro Technologies, Inc.
1166 Kapp Drive, Clearwater, FL, 33765
Phone: 800-756-7946 or 727-562-5186 Fax: 727-562-5187
or visit us on the web at www.clearwater-enviro.com